

ELEVATION

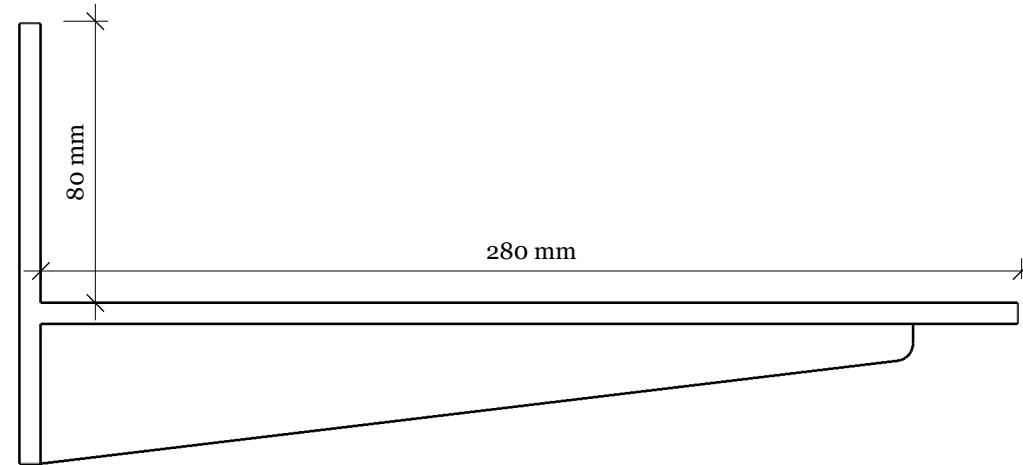

END VIEW

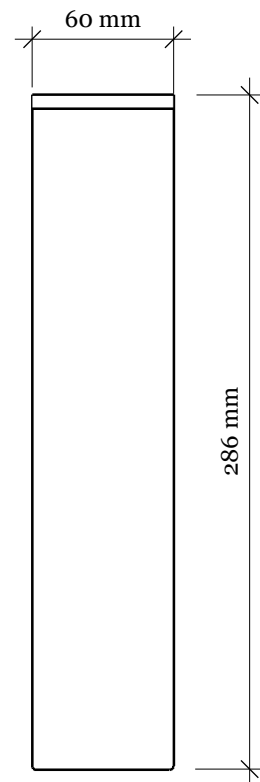

PLAN

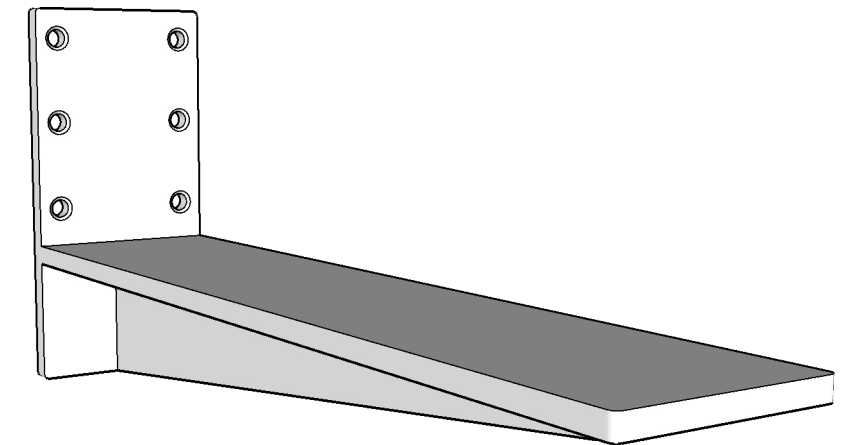

PERSPECTIVE VIEW

2 OF THESE BRACKETS SUPPLIED PER SINK

Concrete Fair work to tolerances of +/-5mm, joints 3-5mm, vertical deflection 3mm per linear meter. It is the responsibility of the customer to check all dimensions are correct and confirm this prior to manufacture/order of basin. Concrete Fair will manufacture basins only from this technical drawing and cannot take any responsibility for incorrect measurements not made known to us prior to manufacture. This drawing is to be used in addition to all other contract documentation and specifications or technical data. All dimensions should be checked and any discrepancy notified to us. Please do not scale from this drawing.

**GREG
BRACKET**



CONCRETE FAIR
SPECIALISED CONCRETE SERVICES

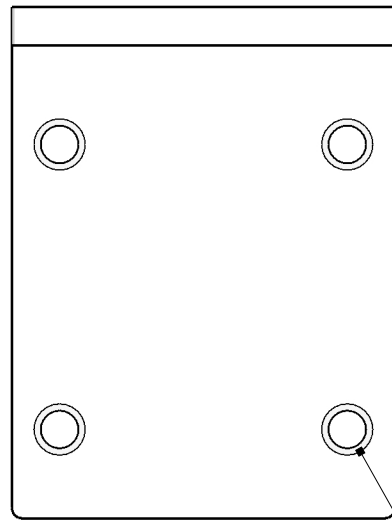

8 mm DIAMETER

ELEVATION

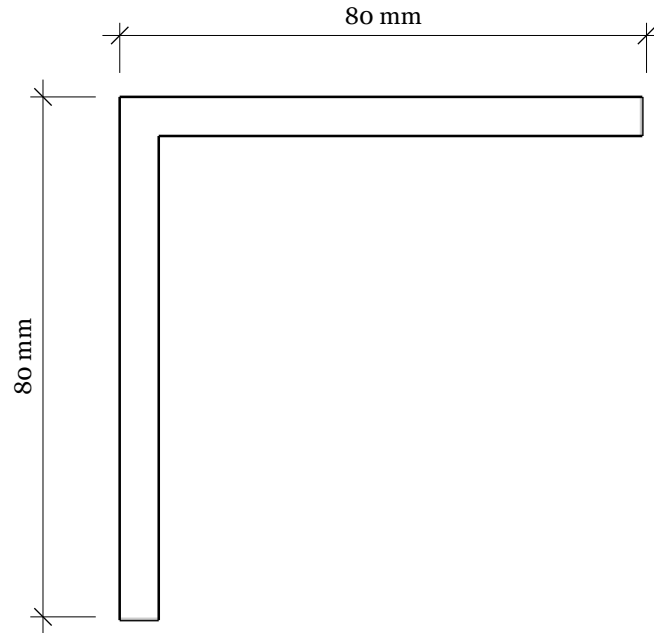

END VIEW

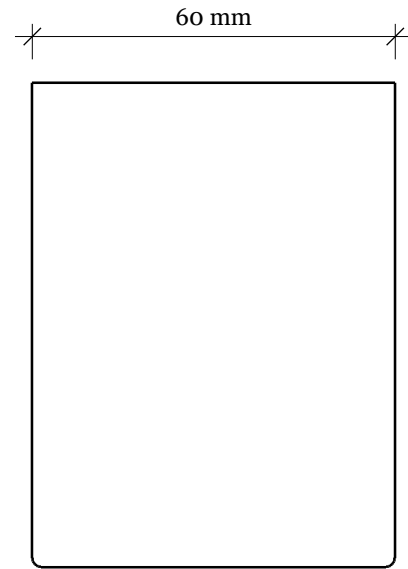

PLAN

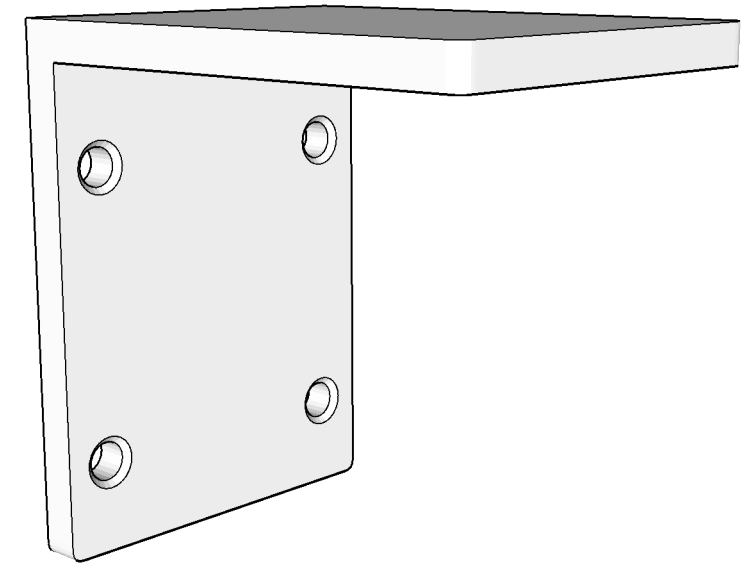

PERSPECTIVE

1 OF THESE BRACKETS SUPPLIED PER SINK

Concrete Fair work to tolerances of +/-5mm, joints 3-5mm, vertical deflection 3mm per linear meter. It is the responsibility of the customer to check all dimensions are correct and confirm this prior to manufacture/order of basin. Concrete Fair will manufacture basins only from this technical drawing and cannot take any responsibility for incorrect measurements not made known to us prior to manufacture. This drawing is to be used in addition to all other contract documentation and specifications or technical data. All dimensions should be checked and any discrepancy notified to us. Please do not scale from this drawing.

**GREG
BRACKET**



CONCRETE FAIR
SPECIALISED CONCRETE SERVICES